

Детали трубопроводов бесшовные приварные  
из углеродистой и низколегированной стали

## ПЕРЕХОДЫ

### Конструкция

Издание официальное

## Предисловие

1 РАЗРАБОТАН ОАО «Корпорация МОНТАЖСПЕЦСТРОЙ»

ВНЕСЕН Государственным комитетом Российской Федерации по стандартизации и метрологии

2 ПРИНЯТ Межгосударственным советом по стандартизации, метрологии и сертификации (протокол № 20 от 1 ноября 2001 г.)

Наименование государства	Наименование национального органа по стандартизации
Азербайджанская Республика	Азгосстандарт
Республика Армения	Армгосстандарт
Республика Беларусь	Госстандарт Республики Беларусь
Грузия	Грузстандарт
Республика Казахстан	Госстандарт Республики Казахстан
Кыргызская Республика	Кыргызстандарт
Республика Молдова	Молдовастандарт
Российская Федерация	Госстандарт России
Республика Таджикистан	Таджикстандарт
Туркменистан	Главгосслужба «Туркменстандартлары»
Республика Узбекистан	Узгосстандарт
Украина	Госстандарт Украины

3 Стандарт соответствует ИСО 3419—81 «Фитинги из легированной и нелегированной стали приварные встык» в части конструкции переходов

4 Постановлением Государственного комитета Российской Федерации по стандартизации и метрологии от 27 мая 2002 г. № 205-ст межгосударственный стандарт ГОСТ 17378—2001 (ИСО 3419—81) введен в действие в качестве государственного стандарта Российской Федерации с 1 января 2003 г.

5 ВЗАМЕН ГОСТ 17378—83

6 ПЕРЕИЗДАНИЕ. Май 2006 г.

© ИПК Издательство стандартов, 2002  
© Стандартинформ, 2006

Настоящий стандарт не может быть полностью или частично воспроизведен, тиражирован и распространен в качестве официального издания на территории Российской Федерации без разрешения Федерального агентства по техническому регулированию и метрологии

Детали трубопроводов бесшовные приварные из углеродистой  
и низколегированной стали

## ПЕРЕХОДЫ

### Конструкция

Carbon and low-alloy steel butt-welding fittings. Reducers. Design

Дата введения 2003—01—01

## 1 Область применения

Настоящий стандарт распространяется на бесшовные приварные концентрические и эксцентрисические переходы из углеродистой и низколегированной стали.

Область применения переходов — в соответствии с разделом 1 ГОСТ 17380.

Требования пунктов 4.1 — 4.3 и раздела 5 являются обязательными, остальные требования — рекомендуемыми.

## 2 Нормативные ссылки

В настоящем стандарте использована ссылка на ГОСТ 17380—2001 (ИСО 3419—81). Детали трубопроводов бесшовные приварные из углеродистой и низколегированной стали. Общие технические условия

## 3 Определения, обозначения и сокращения

Термины, их определения, обозначения и сокращения — по ГОСТ 17380.

## 4 Конструкция и размеры

4.1 Конструкция и размеры переходов должны соответствовать указанным на рисунке 1 и в таблицах 1 и 2.



Рисунок 1

Таблица 1 — Переходы исполнения 1

Размеры в миллиметрах

DN	D	T	D <sub>1</sub>	T <sub>1</sub>	L	Масса, кг
20	26,9	2,0	21,3	2,0	38	0,05
		3,2		3,2		0,07
		4,0		4,0		0,09
25	33,7	2,3	21,3	2,0	51	0,09
		3,2		3,2		0,12
		4,5		4,0		0,16
		2,3	26,9	2,0		0,09
		3,2		3,2		0,12
		4,5		4,0		0,16
32	42,4	2,6	21,3	2,0	51	0,13
		3,6		3,2		0,17
		5,0		4,0		0,23
		2,6	26,9	2,0		0,13
		3,6		3,2		0,17
		5,0		4,0		0,23
32	42,4	2,6	33,7	2,3	51	0,13
		3,6		3,2		0,17
		5,0		4,5		0,23
		2,6	26,9	2,0		0,19
		3,6		3,2		0,25
		5,0		4,0		0,34
40	48,3	2,6	33,7	2,3	64	0,19
		3,6		3,2		0,25
		5,0		4,5		0,34
		2,6	42,4	2,6		0,19
		3,6		3,6		0,25
		5,0		5,0		0,34
50	60,3	2,9	33,7	2,3	76	0,31
		4,0		3,2		0,42
		5,6		4,5		0,58
		2,9	42,4	2,6		0,31
		4,0		3,6		0,42
		5,6		5,0		0,58
50	60,3	2,9	48,3	2,6	76	0,31
		4,0		3,6		0,42
		5,6		5,0		0,58
		2,9	42,4	2,6		0,47
		5,0		3,6		0,78
		7,1		5,0		1,10
65	76,1	2,9	48,3	2,6	89	0,47
		5,0		3,6		0,78
		7,1		5,0		1,10
		2,9	42,4	2,6		0,47
		5,0		3,6		0,78
		7,1		5,0		1,10

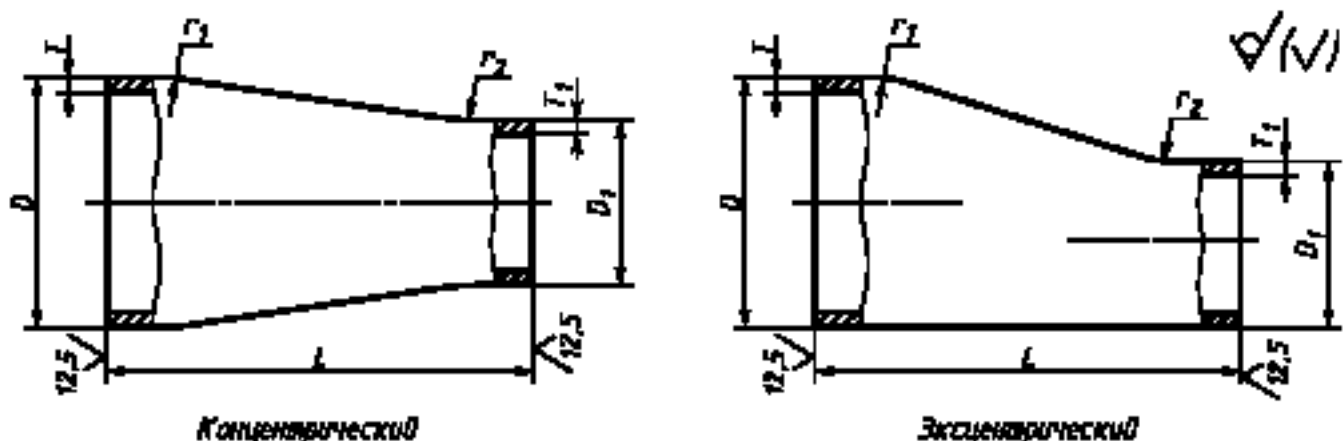
DN	D	T	D <sub>1</sub>	T <sub>1</sub>	L	Масса, кг
65	76,1	2,9	60,3	2,9		0,47
		5,0		4,0		0,78
		7,1		5,6		1,10
80	88,9	3,2	48,3	2,6	89	0,60
		5,6		3,6		1,00
		8,0		5,0		1,40
		3,2	60,3	2,9		0,60
		5,6		4,0		1,00
		8,0		5,6		1,40
		3,2	76,1	2,9		0,60
		5,6		5,0		1,00
		8,0		7,1		1,40
100	114,3	3,6	60,3	2,9	102	1,00
		6,3		4,0		1,70
		8,8		5,6		2,30
		3,6	76,1	2,9		1,00
		6,3		5,0		1,70
		8,8		7,1		2,30
		3,6	88,9	3,2		1,00
		6,3		5,6		1,70
		8,8		8,0		2,30
125	139,7	4,0	76,1	2,9	127	1,70
		6,3		5,0		2,60
		10,0		7,1		4,10
		4,0	88,9	3,2		1,70
		6,3		5,6		2,60
		10,0		8,0		4,10
		4,0	114,3	3,6		1,70
		6,3		6,3		2,60
		10,0		8,8		4,10
150	168,3	4,5	88,9	3,2	140	2,50
		7,1		5,6		3,90
		11,0		8,8		6,00
		4,5	114,3	3,6		2,50
		7,1		6,3		3,90
		11,0		8,8		6,00
		4,5	139,7	4,0		2,50
		7,1		6,3		3,90
		11,0		10,0		6,00
200	219,1	6,3	114,3	3,6	152	5,10
		8,0		6,3		6,30
		12,5		8,8		9,70

Продолжение таблицы 1

Размеры в миллиметрах

DN	D	T	D <sub>1</sub>	T <sub>1</sub>	L	Масса, кг
200	219,1	6,3 8,0 12,5	139,7	4,0 6,3 10,0	152	5,10 6,30 9,70
		6,3 8,0 12,5		4,5 7,1 11,0		5,10 6,30 9,70
250	273,0	6,3 10,0	139,7	4,0 6,3	178	7,40 12,00
		6,3 10,0	168,3	4,5 7,1		7,40 12,00
		6,3 10,0	219,1	6,3 8,0		7,40 12,00
300	323,9	7,1 10,0	168,3	4,5 7,1	203	11,00 16,00
		7,1 10,0	219,1	6,3 8,0		11,00 16,00
		7,1 10,0	273,0	6,3 10,0		11,00 16,00
350	355,6	8,0 11,0	219,1	6,3 8,0	330	23,00 31,00
		8,0 11,0	273,0	6,3 10,0		23,00 31,00
		8,0 11,0	323,9	7,1 10,0		23,00 31,00
400	406,4	8,8 12,5	273,0	6,3 10,0	356	31,00 43,00
		8,8 12,5	323,9	7,1 10,0		31,00 43,00
		8,8 12,5	355,6	8,0 11,0		31,00 43,00
450	457,0	10,0	323,9	7,1	381	42,00
			355,6	8,0		
			406,4	8,8		
500	508,0	11,0	355,6	8,0	508	65,00
			406,4	8,8		
			457,0	10,0		

DN	D	T	D <sub>1</sub>	T <sub>1</sub>	L	Масса, кг
600	610,0	12,5	406,4	8,8	508	94,0
			457,0	10,0		
			508,0	11,0		
700	711,0	—	457,0	10,0	610	—
			508,0	11,0		
			610,0	12,5		
800	813,0	—	508,0	11,0	610	—
			610,0	12,5		
			711,0	—		
900	914,0	—	610,0	12,5	610	—
			711,0	—		
			813,0	—		
1000	1016,0	—	711,0	—	610	—
			813,0	—		
			914,0	—		

Примечание — Масса приведена для сплавов.

Таблица 2 — Переходы исполнения 2

DN	D	T	D <sub>1</sub>	T <sub>1</sub>	L	Масса, кг
32	38	2,0	32	2,0	30	0,1
		3,0		3,0		0,2
		4,0		4,0		0,2
		2,0	25	1,6		0,1
		3,0		3,0		0,2
		4,0		3,0		0,2
40	45	2,5	32	1,6	30	0,1
		4,0		3,0		0,2
		5,0		3,0		0,3
		2,5	32	2,0		0,1
		4,0		4,0		0,2
		5,0		5,0		0,3
50	57	2,5	38	2,0	45	0,1
		4,0		4,0		0,2
		5,0		5,0		0,3
		3,0	25	1,6		0,2
		4,0		1,6		0,3
		5,0		3,0		0,3
		6,0		3,0		0,4

Продолжение таблицы 2

Размеры в миллиметрах

DN	D	r	D <sub>1</sub>	r <sub>1</sub>	L	Масса, кг		
50	57	3,0	32	2,0	45	0,2		
		4,0		2,0		0,3		
		5,0		3,0		0,3		
		6,0		4,0		0,4		
		3,0	38	2,0		60	0,2	
		4,0		4,0			0,3	
		5,0		4,0			0,3	
		6,0		4,0			0,4	
		3,0	45	2,5	60	0,2		
		4,0		2,5		0,3		
		5,0		4,0		0,3		
		6,0		5,0		0,4		
65	76	3,0	38	2,0	55	0,3		
		3,5		2,5		0,4		
		5,0		3,0		0,6		
		6,0		3,0		0,6		
		7,0		4,0		0,7		
		3,0	45	2,5	70	0,4		
		3,5		2,5		0,5		
		5,0		4,0		0,6		
		6,0		4,0		0,7		
		7,0	5,0	0,8				
		3,0	57	3,0		70	0,3	
		3,5		3,0			0,4	
5,0	4,0	0,6						
6,0	5,0	0,7						
7,0	6,0	0,8						
80	89	3,5	45	2,5	75	0,6		
		6,0		4,0		0,9		
		8,0		5,0		1,2		
		3,5	57	3,0		75	0,6	
		6,0		4,0			0,9	
		8,0		5,0			1,2	
		3,5	76	3,5			75	0,6
		6,0		5,0				0,9
		8,0		6,0				1,2
100	108	4,0	57	3,0	80			0,9
		6,0		4,0				1,2
		8,0		5,0				1,6
		9,0		6,0		1,8		
		4,0	76	3,5		80		0,9
		6,0		5,0				1,2
		8,0		6,0			1,6	
		9,0		7,0			1,8	



DN	D	T	D <sub>1</sub>	T <sub>1</sub>	L	Масса, кг	
100	108	4,0	89	3,5	80	0,9	
		6,0		6,0		1,2	
		8,0		8,0		1,6	
		9,0		8,0		1,8	
	114	4,0	57	3,0		1,0	
				6,0		4,0	1,3
				8,0		5,0	1,7
				9,0		6,0	1,9
		76	4,0	3,5		1,0	
			6,0	5,0		1,3	
			8,0	6,0		1,7	
			9,0	7,0		1,9	
89	4,0	3,5	1,0				
	6,0	6,0	1,3				
	8,0	8,0	1,7				
	9,0	8,0	1,9				
125	133	4,0	57	3,0	100	1,3	
				8,0		4,0	2,5
				10,0		5,0	3,1
		5,0	76	3,5		1,6	
				8,0		5,0	2,5
				10,0		6,0	3,1
	4,0	89	3,5	1,3			
			5,0	1,9			
			6,0	2,5			
	5,0	108	4,0	1,6			
			8,0	6,0		2,5	
			8,0	8,0		2,5	
	10,0	114	4,0	9,0		3,1	
			5,0	4,0		1,6	
			8,0	6,0		2,5	
8,0	114	8,0	8,0	2,5			
		10,0	9,0	3,1			
		9,0	9,0	3,1			
150	159	4,5	57	3,0	75	1,5	
				8,0		4,0	2,6
				10,0		5,0	3,2
				12,0		6,0	3,9
		4,5	76	3,5		1,5	
				5,0		2,6	
	10,0	76	6,0	3,2			
			7,0	3,9			
	4,5	89	89	3,5	130	2,3	
				8,0		6,0	3,9
				10,0		8,0	4,8
				12,0		8,0	5,9

Продолжение таблицы 2

Размеры в миллиметрах

DN	D	T	D <sub>1</sub>	T <sub>1</sub>	L	Масса, кг	
150	159	4,5	108	4,0	130	2,3	
		8,0		6,0		3,9	
		10,0		8,0		4,8	
		12,0		9,0		5,9	
		4,5	114	4,0		2,3	
		8,0		6,0		3,9	
		10,0		8,0		4,8	
		12,0		9,0		5,9	
		4,5	133	4,0		2,3	
	8,0	8,0		3,9			
	10,0	10,0		4,8			
	12,0	10,0		5,9			
	168	57	4,5	57	3,0	75	1,6
			8,0		4,0		2,7
			10,0		5,0		3,3
		12,0	6,0	4,0			
		4,5	76	3,5	1,6		
		8,0		5,0	2,7		
10,0		6,0		3,3			
12,0		7,0		4,0			
130		168	4,5	89	3,5		130
	8,0		6,0		4,1		
	10,0		8,0		5,1		
	12,0		8,0	6,2			
	4,5		108	4,0	2,6		
	8,0			6,0	4,1		
10,0	8,0	5,1					
12,0	9,0	6,2					
4,5	114	4,0	2,6				
8,0		6,0	4,1				
10,0		8,0	5,1				
12,0	9,0	6,2					
4,5	133	4,0	2,6				
8,0		8,0	4,1				
10,0		10,0	5,1				
12,0	10,0	6,2					
200	219	6,0	57	3,0	95	2,9	
		10,0		4,0		4,6	
		12,0		4,0		5,5	
		14,0		5,0		6,4	
		16,0		6,0		7,3	
		6,0		76		3,5	2,9
10,0	5,0	4,6					
12,0	5,0	5,5					
14,0	6,0	6,4					
16,0	7,0	7,3					

DN	D	T	D <sub>1</sub>	T <sub>1</sub>	L	Масса, кг	
200	219	6,0	89	3,5	95	2,9	
		10,0		5,0		4,6	
		12,0		5,0		5,5	
		14,0		6,0		6,4	
		16,0		8,0		7,3	
		6,0	108	4,0		2,9	
		10,0		6,0		4,6	
		12,0		8,0		5,5	
		14,0		8,0		6,4	
		16,0		9,0		7,3	
		6,0	114	4,0		2,9	
		10,0		6,0		4,6	
		12,0		8,0		5,5	
		14,0		8,0		6,4	
		16,0		9,0		7,3	
		6,0	133	4,0		140	4,4
		10,0		8,0			7,2
		12,0		8,0			8,8
14,0	10,0	10,0					
16,0	10,0	12,0					
6,0	159	4,5	4,4				
10,0		8,0	7,2				
12,0		10,0	8,8				
14,0		12,0	10,0				
16,0		12,0	12,0				
6,0	168	4,5	4,4				
10,0		8,0	7,2				
12,0		10,0	8,8				
14,0		12,0	10,0				
16,0		12,0	12,0				
250	273	7,0	108	4,0	140		6,0
		10,0		6,0			8,5
		12,0		8,0			10,0
		14,0		8,0		12,0	
		16,0		9,0		13,0	
		18,0	9,0	15,0			
		7,0	114	4,0		6,0	
		10,0		6,0		8,5	
		12,0		8,0		10,0	
		14,0		8,0		12,0	
		16,0		9,0		13,0	
		18,0	9,0	15,0			
		7,0	133	4,0		6,0	
		10,0		6,0		8,5	
		12,0		8,0		10,0	
14,0	8,0	12,0					
16,0	10,0	13,0					
18,0	10,0	15,0					

Продолжение таблицы 2

Размеры в миллиметрах

DN	D	T	D <sub>1</sub>	T <sub>1</sub>	L	Масса, кг
250	273	7,0	159	4,5	180	8,3
		10,0		8,0		12,0
		12,0		10,0		14,0
		14,0		10,0		16,0
		16,0		12,0		18,0
		18,0		12,0		20,0
		7,0	168	4,5		8,3
		10,0		8,0		12,0
		12,0		10,0		14,0
14,0	10,0	16,0				
16,0	12,0	18,0				
18,0	12,0	20,0				
7,0	219	6,0	8,3			
10,0		8,0	12,0			
12,0		10,0	14,0			
14,0		12,0	16,0			
16,0		14,0	18,0			
18,0		16,0	20,0			
300	325	8,0	108	4,0	140	9,0
		10,0		4,0		11,0
		12,0		6,0		16,0
		14,0		6,0		18,0
		16,0		8,0		20,0
		18,0		8,0		23,0
		22,0		9,0		28,0
		8,0	114	4,0		9,0
		10,0		4,0		11,0
		12,0		6,0		16,0
		14,0		6,0		18,0
		16,0		8,0		20,0
		18,0	8,0	23,0		
		22,0	9,0	28,0		
		8,0	133	5,0		11,0
		10,0		6,0		13,0
		12,0		8,0		16,0
		14,0		8,0		18,0
		16,0		8,0		20,0
		18,0		10,0		23,0
22,0	10,0	28,0				
8,0	159	4,5	11,0			
10,0		6,0	14,0			
12,0		8,0	16,0			
14,0		8,0	18,0			
16,0		10,0	20,0			
18,0		10,0	23,0			
22,0	12,0	28,0				
8,0	168	4,0	11,0			
10,0		6,0	14,0			
12,0		8,0	16,0			
14,0		8,0	18,0			
14,0		8,0	18,0			

DN	D	T	D <sub>1</sub>	T <sub>1</sub>	L	Масса, кг	
300	325	16,0	168	10,0	140	20,0	
		18,0		10,0		23,0	
		22,0		12,0		28,0	
		8,0	219	7,0		180	11,0
		10,0		8,0			14,0
		12,0		10,0			17,0
	14,0	10,0		20,0			
	16,0	12,0		22,0			
	18,0	14,0		25,0			
	22,0	16,0	31,0				
	350	377	8,0	273	7,0	220	11,0
			10,0		10,0		14,0
12,0			12,0		17,0		
14,0			12,0		20,0		
16,0			14,0		22,0		
18,0			16,0		25,0		
22,0		18,0	31,0				
350		377	12,0	219	6,0	220	22,0
			16,0		8,0		29,0
			20,0		10,0		35,0
			24,0		12,0		42,0
			26,0		12,0		45,0
	12,0		168		6,0		220
	16,0	8,0		29,0			
	20,0	10,0		35,0			
	24,0	12,0		42,0			
	26,0	12,0		45,0			
	12,0	273		8,0	220	22,0	
	16,0		10,0	29,0			
20,0	12,0		35,0				
24,0	14,0		42,0				
26,0	16,0		45,0				
10,0	325		7,0	220		20,0	
12,0		10,0	24,0				
14,0		12,0	28,0				
16,0		12,0	31,0				
20,0		16,0	38,0				
24,0		18,0	45,0				
26,0	22,0	49,0					
400	426	10,0	159	8,0	220	20,0	
		12,0		10,0		24,0	
		14,0		12,0		28,0	
400	426	16,0	159	10,0	220	31,0	
		20,0		18,0		38,0	
		24,0		22,0		45,0	
400	426	20,0	159	10,0	220	49,0	
		12,0		8,0		22,0	
		16,0		10,0		29,0	

Окончание таблицы 2

Размеры в миллиметрах

DN	D	T	D <sub>1</sub>	T <sub>1</sub>	L	Масса, кг	
400	426	22,0	159	10,0	220	71,0	
		26,0		12,0		83,0	
		28,0		12,0		89,0	
		12,0	168	8,0		37,0	
		16,0		10,0			53,0
		20,0		10,0			65,0
		22,0		10,0			71,0
		26,0		12,0			83,0
		28,0		12,0			89,0
		12,0	219	8,0		32,0	
		16,0		10,0			45,0
		20,0		12,0			56,0
22,0	12,0	61,0					
26,0	14,0	72,0					
28,0	16,0	76,0					
12,0	273	10,0	27,0				
16,0		12,0		36,0			
20,0		14,0		44,0			
22,0		14,0		48,0			
26,0		18,0		56,0			
28,0		18,0		59,0			
10,0	325	8,0	23,0				
12,0		10,0		27,0			
14,0		12,0		31,0			
16,0		12,0		36,0			
20,0		16,0		44,0			
22,0		18,0		48,0			
26,0		20,0		56,0			
28,0		22,0		59,0			
10,0	377	10,0	23,0				
12,0		12,0		27,0			
14,0		14,0		31,0			
16,0		16,0		36,0			
20,0		20,0		44,0			
22,0		20,0		48,0			
26,0		24,0		56,0			
28,0		26,0		59,0			
500	530	12,0	377	10,0	300	46,0	
		14,0		12,0		54,0	
		16,0		12,0		61,0	
		20,0		16,0		75,0	
		22,0		20,0		81,0	
		26,0		22,0		94,0	
		12,0	426	10,0		46,0	
		14,0		12,0			54,0
		16,0		16,0			61,0
		20,0		16,0			75,0
22,0		20,0	81,0				
26,0		22,0	94,0				

Примечание — Масса приведена для спиралек.

Примеры условных обозначений:

- концентрического перехода исполнения 1,  $D = 76,1$  мм,  $T = 2,9$  мм,  $D_1 = 48,3$  мм,  $T_1 = 2,6$  мм из стали марки Р9:

*Переход К-1-76,1 × 2,9-48,3×2,6-Р9 ГОСТ 17378—2001*

- эксцентрического перехода исполнения 2,  $D = 76$  мм,  $T = 3,0$  мм,  $D_1 = 45$  мм,  $T_1 = 2,5$  мм из стали марки 20:

*Переход Э-76 × 3-45 × 2,5 ГОСТ 17378—2001*

- то же, из стали марки 09Г2С для трубопроводов, подконтрольных органам надзора:

*Переход П Э-76 × 3-45 × 2,5-09Г2С ГОСТ 17378—2001*

4.2 Толщина стенки переходов в неторцевых сечениях должна быть не менее  $T_1$  при наружном диаметре сечения не более  $1,1D_1$ , а в остальных сечениях — не менее  $T$ .

4.3 Радиусы сопряжения поверхностей переходов (рисунок 1) должны соответствовать указанным в таблице 3.

Таблица 3 — Радиусы сопряжения поверхностей переходов

Тип перехода	$r_1$	$r_2$
	не менее	
Концентрический	$0,4D$	$0,4D_1$
Эксцентрический	$0,3D$	$0,3D_1$

4.4 По согласованию между изготовителем и потребителем (заказчиком) допускается изготовление переходов других размеров.

## 5 Технические условия

Технические условия — по ГОСТ 17380.

УДК: 621.643.4:006.354

МКС 23.040.40

Г18

ОКП 14 6800

Ключевые слова: трубопроводы, детали трубопроводов, трубопроводные переходы, конструкция, размеры

**Изменение № 1 ГОСТ 17378—2001 (ИСО 3419—81) Детали трубопроводов бесшовные приварные из углеродистой и низколегированной стали. Переходы. Конструкция**

Принято Межгосударственным советом по стандартизации, метрологии и сертификации (протокол № 29 от 24.06.2006)

Зарегистрировано Бюро по стандартам МГС № 5422

За принятие изменения проголосовали национальные органы по стандартизации следующих государств: AM, KZ, KG, MD, RU, TJ, UZ, UA [коды альфа-2 по МК (ИСО 3166) 004]

Дату введения в действие настоящего изменения устанавливают указанные национальные органы по стандартизации\*

Раздел 2. Заменить ссылку: ГОСТ 17380—2001 на ГОСТ 17380—2001 (ИСО 3419—81).

Пункт 4.1. Таблицу 2 дополнить размерами:

DN	D	T	D <sub>1</sub>	T <sub>1</sub>	L	Масса, кг
50	57	3,0	45	2,5	45	0,2
		3,5		2,5		0,2
		4,0		3,0		0,3
		5,0		4,0		0,3
		6,0		5,0		0,4
80	89	3,5	76	3,0	55	0,5
		4,0		3,5		0,5
		6,0		5,0		0,7
		8,0		6,0		0,9
125	133	5,0	108	4,0	80	1,3
		6,0		5,0		1,6
		8,0		7,0		2,0
		10,0		9,0		2,5
		5,0	114	4,5		1,3
		6,0		5,0		1,6
		8,0		6,0		2,0
		10,0		8,0		2,5

\* Дата введения в действие на территории Российской Федерации — 2008—01—01.

(Продолжение см. с. 42)



Окончание таблицы

DN	D	T	D <sub>1</sub>	T <sub>1</sub>	L	Масса, кг
150	159	5,0	114	4,0	105	2,0
		6,0		5,0		2,5
		8,0		6,0		3,1
		10,0		8,0		3,8
		5,0	133	4,5		2,0
		6,0		5,0		2,5
		8,0		7,0		3,1
		10,0		9,0		3,8

Пункт 4.3. Первый абзац изложить в новой редакции:

«Радиусы  $r_1$  и  $r_2$  переходов исполнения 1 должны соответствовать указанным в таблице 3, а исполнения 2 устанавливаются изготовителем в конструкторской документации с учетом применяемой технологии изготовления и обеспечения требуемых показателей прочности и надежности»;

таблица 3. Наименование после слова «переходов» дополнить словами: «исполнения 1».

(ИУС № 7 2007 г.)

**Изменение № 1 ГОСТ 17378—2001 (ИСО 3419—81) Детали трубопроводов бесшовные приварные из углеродистой и низколегированной стали. Переходы. Конструкция**

Принято Межгосударственным советом по стандартизации, метрологии и сертификации (протокол № 29 от 24.06.2006)

Зарегистрировано Бюро по стандартам МГС № 5422

За принятие изменения проголосовали национальные органы по стандартизации следующих государств: AM, KZ, KG, MD, RU, TJ, UZ, UA [коды альфа-2 по МК (ИСО 3166) 004]

Дату введения в действие настоящего изменения устанавливают указанные национальные органы по стандартизации\*

Раздел 2. Заменить ссылку: ГОСТ 17380—2001 на ГОСТ 17380—2001 (ИСО 3419—81).

Пункт 4.1. Таблицу 2 дополнить размерами:

DN	D	T	D <sub>1</sub>	T <sub>1</sub>	L	Масса, кг
50	57	3,0	45	2,5	45	0,2
		3,5		2,5		0,2
		4,0		3,0		0,3
		5,0		4,0		0,3
		6,0		5,0		0,4
80	89	3,5	76	3,0	55	0,5
		4,0		3,5		0,5
		6,0		5,0		0,7
		8,0		6,0		0,9
125	133	5,0	108	4,0	80	1,3
		6,0		5,0		1,6
		8,0		7,0		2,0
		10,0		9,0		2,5
		5,0	114	4,5		1,3
		6,0		5,0		1,6
		8,0		6,0		2,0
		10,0		8,0		2,5

\* Дата введения в действие на территории Российской Федерации — 2008—01—01.

(Продолжение см. с. 42)

Окончание таблицы

DN	$D$	$T$	$D_1$	$T_1$	$L$	Масса, кг
150	159	5,0	114	4,0	105	2,0
		6,0		5,0		2,5
		8,0		6,0		3,1
		10,0		8,0		3,8
		5,0	133	4,5		2,0
		6,0		5,0		2,5
		8,0		7,0		3,1
		10,0		9,0		3,8

Пункт 4.3. Первый абзац изложить в новой редакции:

«Радиусы  $r_1$  и  $r_2$  переходов исполнения 1 должны соответствовать указанным в таблице 3, а исполнения 2 устанавливаются изготовителем в конструкторской документации с учетом применяемой технологии изготовления и обеспечения требуемых показателей прочности и надежности»;

таблица 3. Наименование после слова «переходов» дополнить словами: «исполнения 1».

(ИУС № 7 2007 г.)